

*(On Non-Judicial Stamp Paper of Rs. 300/- attested by Notary Public/ First Class Magistrate)*

**NIT No: UGVCL/Project/Solar/PM-KUSUM-C-FLS/TN-7**

**K.18. DRAFT Power Purchase Agreement(PPA)**

**POWERPURCHASEAGREEMENT**

for

Procurement of \_\_\_\_ MWp

Solar Power on Long Term basis under

Feeder level Solarization -Component-C of

PM-KUSUM Component-C Scheme for

\_\_\_\_\_ 11 KV Feeder(s) of \_\_\_\_\_ 66/11 KV Substation,

\_\_\_\_\_ sub-division, \_\_\_\_\_ Division, \_\_\_\_\_ Circle of

Between

*<nameofSolarPowerGenerator(SPG)>*

and

**UTTAR GUJARAT VIJ COMPANYLIMITED**

[ \_\_\_\_\_ 2022]

This Power Purchase Agreement is made on the \_\_\_\_\_ day of \_\_\_\_\_ of 20 at \_\_\_\_\_.

Between

.....<name of SPG>....., selected as Solar Power Generator for implementation of Solar Power Project with associated 11kV line under **Pradhan Mantri Kisan Urja Suraksha evam Utthan Mahabhiyan (PM KUSUM) Scheme Component C (feeder level solarization)**, having registered office at .....<Address of SPG>..... (hereinafter referred to as **"Solar Power Generator or SPG"**, which expressions shall, unless repugnant to the context or meaning thereof, be deemed to include its successors and permitted assigns) as a Party of the **First Part**;

**And**

**UTTAR GUJARAT VIJ COMPANY LIMITED'** a company incorporated under the Companies Act 1956, having its registered office at, \_\_\_\_\_ (hereinafter referred to as " " which expression shall, unless repugnant to the context or meaning thereof, be deemed to include its successors and assignees) as a Party of the **Second Part**;

The SPG and are individually referred to as 'Party' and collectively referred to as 'Parties'.

**WHEREAS:**

- A.** The Ministry of New and Renewable Energy [MNRE] has launched a guidelines for feeder level solarization under Component C of PM KUSUM Scheme on 04<sup>th</sup> Dec 2020.
- B.** initiated a selection process for Solar Power Generator (SPG) to set up \_\_\_\_\_ MWp solar power plant through RESCO mode and procurement of power generated from the solar power plant as per the terms and conditions contained in the RfS No: \_\_\_\_\_ DT: \_\_\_\_\_
- C.** The SPG has been selected for the work of design, survey, supply, installation, testing, commissioning and operation & maintenance of grid connected \_\_\_\_\_ MWp solar power plant, its associated 11kV line to connect the plant with concerned substation and RMS of solar power plant for Solarization of \_\_\_\_\_ 11kV feeder(s) of 66/11kV \_\_\_\_\_ substation under \_\_\_\_\_ subdivision, \_\_\_\_\_ Division, \_\_\_\_\_ Circle of \_\_\_\_\_.
- D.** has issued the Letter of Award/Work Order No. .... dated ..... in favour of .....<name of SPG> as per the terms and conditions contained in the RfS.
- E.** The SPG has furnished the Project Security Amount of **Rs.** \_\_\_\_\_

( \_\_\_\_\_ rupees only) in the form of Bank Guarantee in favour of, \_\_\_\_\_.

- F.** The SPG has fulfilled the terms and conditions for signing this Power Purchase Agreement as a definitive agreement for establishing the Solar Power Project of \_\_\_ **MWp** under Feeder level solarization –Component-C of PM-KUSUM Scheme for \_\_\_\_\_ feeder(s) of \_\_\_\_\_ 66/11kV substation, \_\_\_\_\_ sub-division, \_\_\_\_\_ division, \_\_\_\_\_ circle of \_\_\_\_\_ under \_\_\_\_\_ district and sale of electricity by the SPG to a 66/11kV \_\_\_\_\_ substation.
- G.** Hon’ble GERC vide judgement dated \_\_\_\_\_ in petition no. \_\_\_\_\_ has adopted the tariff discovered in the competitive bidding process conducted vide RfS dated \_\_\_\_\_ wherein the SPG has emerged as a successful bidder.
- H.** The parties have agreed to execute this Power Purchase Agreement in terms of the RfS and the Letter of Award in regard to the work of Design, survey, supply, installation, testing, commissioning, operation & maintenance for 25 years (unless extended by both the parties on mutual agreement) from COD of grid connected Feeder level solar power plant having capacity of \_\_\_\_\_ MW, its associated 11kV line to connect the plant with concerned substation and RMS of solar power plant through RESCO model for solarization of \_\_\_\_\_ 11kV feeders of associated \_\_\_\_\_ 66/11kV substation in under PMKUSUM scheme – Component C (feeder level solarization) Now therefore, in consideration of the premises and mutual agreements, covenants and conditions set forth herein, it is hereby agreed by and between the Parties as follows

**ARTICLE 1: DEFINITIONS AND INTERPRETATION**

**1.1 Definitions**

The terms used in this Agreement, unless as defined below or repugnant to the context, shall have the same meaning as assigned to them by the Electricity Act, 2003 and the rules or regulations framed thereunder, including those issued/framed by the Appropriate Commission (as defined hereunder), as amended or re-enacted from time to time.

“Electricity Act, 2003”	shall mean the Electricity Act, 2003 and include any modifications, amendments and substitution from time to time;
“Agreement” or “Power Purchase Agreement” or	shall mean this Power Purchase Agreement including its recitals and Schedules, amended or modified from time to time in accordance with the terms hereof;

"PPA"	
"Appropriate Commission"	Appropriate Commissioner "GERC" shall mean the Gujarat Electricity Regulatory Commission (GERC)
"Bill Dispute Notice"	shall mean the notice issued by a Party raising a Dispute regarding a Monthly Bill or a Supplementary Bill issued by the other Party;
"Base rate of Late Payment Surcharge"	shall mean the marginal cost of funds based lending rate for one year of the State Bank of India, as applicable on the 1st April of the financial year in which the period lies, plus five percent and in the absence of marginal cost of funds based lending rate, any other arrangement that substitutes it, which the Central Government may, by notification, in the Official Gazette, specify. Provided that if the period of default lies in two or more financial years, the base rate of Late Payment Surcharge shall be calculated separately for the periods falling in different years.
"Business Day"	shall mean with respect to SPG and DISCOM, a day other than Sunday or a statutory holiday, on which the banks remain open for business in the State;
"Capacity Utilisation Factor" or "CUF"	CUF in a Year shall mean the ratio of the net output energy injected at delivery point of the SPV Power Plant in a Year versus installed Project capacity $\times 365 \times 24$ (i.e. $CUF = \frac{\text{Cumulative Project output in kWh}}{(\text{installed Project capacity in kW} \times 24 \times 365)}$ ) The annual CUF will be calculated every year from 1st April of the year (COD for first year) to 31 <sup>st</sup> March next year.
"CFA"	Shall mean the Central Finance Assistance to be provided by the Ministry of New and Renewable Energy Government of India under the Pradhan Mantri Urja Suraksha evam Utthaan Mahabhiyaan (PM-KUSUM) scheme as per the Guidelines for Implementation of Feeder Level Solarisation under Component-C of PM-KUSUM Scheme issued on date 4-12-2020 with subsequent amendment/s, if any.
"Change in Law"	shall have the meaning ascribed thereto in Article 12 of this Agreement;
"Commercial Operation Date (COD)"	shall mean the date certified by the DISCOM's committee upon successful commissioning (as per provisions of this Agreement) of the project when all equipments as per rated capacity have been installed and energy has flown into the grid.
"Competent Court of Law"	shall mean the Supreme Court of India or Gujarat High Court, or any tribunal or any similar judicial or quasi-judicial

	body that has jurisdiction in relation to issues relating to the Project.
“Consents,Clearances andPermits	shall mean all authorizations, licenses, approvals,registrations, permits, waivers, privileges,acknowledgements, agreements, or concessions requiredto be obtained from or provided by any concernedauthorityforthepurpose of settingup ofthegeneration facilitiesand/or supplyof power;
“Consultation Period”	shall mean the period of ninety (90) days or such otherlonger period as the Parties may agree, commencing fromthe date of issuance of a SPGPreliminary Default Noticeor DISCOM Preliminary Default Notice as provided inArticle 13 of this Agreement, for consultation between thePartiestomitigatethe consequenceof therelevantevent havingregardtoallthecircumstances;
“ContractYear”	shall mean the period beginning from the Effective Dateand ending on the immediately succeeding March 31 andthereafter each period of 12 months beginning on April 1andendingon March31providedthat: 1) in the financial year in which the COD occurs, theContract Year shall end on the date immediatelybefore the COD and a new Contract Year shallcommence once again from the COD and end on theimmediately succeeding March 31, andthereaftereach period oftweleve (12)months commencing onApril1andendingon March31,and 2) provided further that the last Contract Year of thisAgreement shallendonthelastdayoftheTermof thisAgreement or on termination of this agreement whichever is earlier.
"Contracted Capacity"	shall mean <u>      </u> <b>MWpAC</b> contracted with DISCOM for supplybytheSPG toDISCOMattheDeliveryPoint which shall be the maximum injection limit at delivery point in any 15 minute time block during the entire term of the PPA.
“DeliveryPoint”	DeliveryPoint”shallmeanthepointatthevoltagelevelof 11kVofthe66/11kVSub-stationi.e.11kVside of 66/11kV <u>      </u> substation under this PPA.Metering shall be done at this interconnection pointwherethepowerisinjectedintothe66/11kV Sub-station. For interconnection with grid and metering, theSPG shall abide by the relevant and applicable regulations,Grid Code notified by the State Commission and CentralElectricity Authority (Installation and Operation of Meters)Regulations, 2006 as amended and revised from time totime, or orders passed thereunder by the AppropriateCommission or CEA. All charges and losses related toTransmissionofpowerfromprojectuptoDeliveryPointshallb eborne bythe SPG without any reimbursement thereof.

“Dispute”	shall mean any dispute or difference of any kind between DISCOM and the SPG, in connection with or arising out of this Agreement including but not limited to any issue on the interpretation and scope of the terms of this Agreement as provided in Article 16 of this Agreement;
DISCOM	Shall mean the Electricity Distribution Company. The DISCOM in this PPA is .
"Due Date"	Due Date shall mean the thirtieth (30 <sup>th</sup> ) day after a Monthly Bill (including all the relevant documents) or a Supplementary Bill is received in hard copy and duly acknowledged by or, if such day is not a Business Day, the immediately succeeding Business Day, by which dates such Monthly Bill or a Supplementary Bill is payable by.
“Effective Date”	shall have the meaning ascribed thereto in Article 2.1 of this Agreement;
“Electricity Laws”	shall mean the Electricity Act, 2003 and the rules and regulations made there under from time to time along with amendments thereto and replacements thereof and any other Law pertaining to electricity including regulations framed by the Appropriate Commission;
“Event of Default”	shall mean the events as defined in Article 13 of this Agreement;
“Expiry Date”	Shall mean the date occurring twenty-five (25) years from the Commercial Operation Date provided that the supply of power shall be limited for a period of 25 years from the COD (unless extended by both the parties on mutual agreement);
“Financing Agreements”	shall mean the agreements pursuant to which the SPG has sought financing for the Power Project including the loan agreements, security documents, for the Power Project including the loan agreements, security documents, notes, indentures, security agreements, letters of credit and other documents, as may be amended, modified, or replaced from time to time, but without in any way increasing the liabilities of ;
"Force Majeure" or "Force Majeure Event"	shall have the meaning ascribed thereto in Article 11 of this Agreement;

“Indian Government Instrumentality”	shall mean the Government of India, Governments of state of Gujarat and any ministry, department, board, authority, agency, corporation, commission under the direct or indirect control of Government of India or the above state Government or both, any political subdivision of any of them including any court or Appropriate Commission or tribunal or judicial or quasi-judicial body in India
“Insurances”	shall mean the insurance cover to be obtained and maintained by the SPG in accordance with Article 8 of this Agreement;
"Interconnection Facilities"	shall mean the facilities on SPG’s side of the Delivery Point for scheduling, transmitting and metering the electrical output in accordance with this Agreement and which shall include, without limitation, all other transmission lines and associated equipment, transformers, relay and switching equipment and protective devices, safety equipment and RTU, Data Transfer and Acquisition facilities for transmitting data subject to Article 7, the Metering System required for supply of power as per the terms of this Agreement;
“Invoice” or “Bill”	shall mean either a Monthly Bill / Supplementary Bill or a Monthly Invoice/ Supplementary Invoice raised by any of the Parties;
“Joint Meter Reading” or “JMR”:	Shall mean the monthly joint meter reading statement which shall be jointly signed by SPG and representative
“Late Payment Surcharge”	shall have the meaning ascribed thereto in Article 10.1.7 of this Agreement;
Law"	shall mean in relation to this Agreement, all laws including Electricity Laws in force in India and any statute, ordinance, regulation, notification or code, rule, or any interpretation of any of them by an Indian Governmental Instrumentality and having force of law and shall further include without limitation all applicable rules, regulations, orders, notifications by an Indian Governmental Instrumentality pursuant to or under any of them and shall include without limitation all rules, regulations, decisions and orders of the GERC;
“Letter of Credit” or “LC”	shall have the meaning ascribed thereto in Article 10.1.10 of this Agreement;
“Letter of Award” or “LoA”	shall mean work order issued by the SPG for the project;
MNRE”	shall mean the Ministry of New and Renewable Energy, Government of India;

"Month"	shall mean a period of thirty (30) days from (and excluding) the date of the event, where applicable, else a calendar month;
"Party" and "Parties"	shall have the meaning ascribed thereto in the recital to this Agreement;
"Payment Security Mechanism"	shall have the meaning ascribed thereto in Article 10.1.10 of this Agreement
"PM-KUSUM"	Pradhan Mantri Urja Suraksha evam Utthaan Mahabhiyaan- A scheme notified by the Ministry of New and Renewable Energy Government of India with Guidelines for Implementation of Feeder Level Solarisation under Component-C of PM-KUSUM Scheme issued on date 4-12-2020.
"Power Project" or "Project"	shall mean the Solar Power generation facility of Contracted Capacity having a separate control system, metering and separate points of injection into the grid at Delivery point. The Project shall include all units and auxiliaries such as water supply, treatment or storage facilities, bay(s) for transmission system in the switchyard, dedicated electrical line upto the Delivery Point and all the other assets, buildings/structures, equipment, plant and machinery, facilities and related assets required for the efficient and economic operation of the power generation facility, whether completed or at any stage of development and construction or intended to be developed and constructed for the purpose of supply of power as per this Agreement;.
"Preliminary Default Notice"	shall have the meaning ascribed thereto in Article 13 of this Agreement;
"Project Capacity"	shall mean the <b>maximum AC</b> capacity of the Project at the point of injection for which the Power Purchase Agreement has been signed.
"Prudent Utility Practices"	shall mean the practices, methods and standards that are generally accepted internationally from time to time by electric utilities for the purpose of ensuring the safe, efficient and economic design, construction, commissioning, operation and maintenance of power generation equipment and which practices, methods and standards shall be adjusted as necessary to take account of: <ul style="list-style-type: none"> <li>a. operation and maintenance guidelines recommended by the manufacturers of the plant and equipment to be incorporated in the Power Project</li> <li>b. the requirements of Indian Law; and the physical conditions at the site of the Power Project</li> </ul>



"Rebate"	shall have the same meaning as ascribed thereto in Article 10.1.9 of this Agreement;
"RESCO"	shall mean Renewable Energy Service Company i.e. an energy service company that develops, installs, finances, operates and owns the solar power project and supplies power generated from the Project to the.
"Rupees", "Rs.",	shall mean Indian rupees, the lawful currency of India;
"Scheduled Commissioning Date" or "SCD" of the Project	Shall mean date that is nine (9) Months from the Date of execution of this PPA between _
"Tariff"	Shall have the same meaning as provided for in Article 9 of this Agreement;
"Tariff Payment"	shall mean the payments to be made under Monthly Bills as referred to in Article 10 and the relevant Supplementary Bills;
"Termination Notice"	shall mean the notice given by either Parties for termination of this Agreement in accordance with Article 13 of this Agreement;
"Term of Agreement"	shall have the meaning ascribed thereto in Article 2 of this Agreement;

## **1.2 INTERPRETATION**

Savewhere the contrary is indicated, any reference in this Agreement to:

- i) *"Agreement"* shall be construed as including a reference to its Schedules, Appendices
- ii) An *"Article"*, a *"Recital"*, a *"Schedule"* and a *"paragraph/ clause"* shall be construed as a reference to an Article, a Recital, a Schedule and a paragraph/ clause respectively of this Agreement;
- iii) A *"crore"* means a reference to ten million (10,000,000) and a *"lakh"* means a reference to one tenth of a million (1,00,000).
- iv) An *"encumbrance"* shall be construed as a reference to a mortgage, charge, pledge, lien or other encumbrance securing any obligation of any person or any other type of preferential arrangement (including, without limitation, title transfer and retention arrangements) having a similar effect;
- v) *"Indebtedness"* shall be construed so as to include any obligation (whether incurred as principal or surety) for the payment or repayment of money, whether present or future, actual or contingent;
- vi) A *"person"* shall be construed as a reference to any person, firm, company, corporation, society, trust, government, state or agency of a state or any association or partnership (whether or not having separate legal personality) of two or more of the above and a person shall be construed as including a reference to its successors, permitted

- transferees and permitted assigns in accordance with their respective interests;
- vii) "*Rupee*", "*Rupees*" and "*Rs.*" shall denote Indian Rupees, the lawful currency of India;
  - viii) The "*winding-up*", "*dissolution*", "*insolvency*", or "*reorganization*" of a company or corporation shall be construed so as to include any equivalent or analogous proceedings under the Law of the jurisdiction in which such company or corporation is incorporated or any jurisdiction in which such company or corporation carries on business including the seeking of liquidation, winding-up, reorganization, dissolution, arrangement, protection or relief of debtors;
  - ix) Words importing the singular shall include the plural and vice versa;
  - x) This Agreement itself or any other agreement or document shall be construed as a reference to this or to such other agreement or document as it may have been, or may from time to time be, amended, varied, novated, replaced or supplemented;
  - xi) A Law shall be construed as a reference to such Law including its amendments or re-enactments from time to time;
  - xii) A time of day shall, save as otherwise provided in any agreement or document be construed as a reference to Indian Standard Time;
  - xiii) Different parts of this Agreement are to be taken as mutually explanatory and supplementary to each other and if there is any inconsistency between or among the parts of this Agreement, they shall be interpreted in a harmonious manner so as to give effect to each part;
  - xiv) The tables of contents and any headings or sub-headings in this Agreement have been inserted for ease of reference only and shall not affect the interpretation of this Agreement.
  - xv) The words "*hereof*" or "*herein*", if and when used in this Agreement shall mean a reference to this Agreement.
  - xvi) The terms "*including*" or "*including without limitation*" shall mean that any list of examples following such term shall in no way restrict or limit the generality of the word or provision in respect of which such examples are provided.

## **ARTICLE 2: TERM OF AGREEMENT**

### **2.1 Effective Date**

- 2.1.1 This Agreement shall come into effect from the date of its execution by all the parties and such date shall be referred to as the Effective Date.

### **2.2 Term of Agreement**

- 2.2.1 Subject to Article 2.3 and 2.4 of this Agreement, this Agreement shall be valid for

atermfromtheEffectiveDateuntiltheExpiryDate.ThisAgreementmaybeextend ed for a further period at least one hundred eighty (180) days prior to theExpiryDate,on mutuallyagreedtermsandconditions.

- 2.2.2 The SPG is free to operate their plants beyond the Expiry Date if other conditionslikelandlease/RighttoUseofLand(asapplicable),permits,approvalsa ndclearancesetc.allow.Insuchcaseunlessotherwiseagreedby,shallnotbeobligha tedtoprocurepowerbeyondtheExpiry Date.

### **2.3 Early Termination**

- 2.3.1 ThisAgreementshallterminatebeforetheExpiryDateifeitherorSPGterminatesth eAgreement,pursuanttoArticle13ofthis Agreement.

### **2.4 Survival**

- 2.4.1 The expiry or termination of this Agreement shall not affect any accrued rights,obligations and liabilities of the Parties under this Agreement, including the right toreceive penalty as per the terms of this Agreement, nor shall it affect the survival ofany continuing obligations for which this Agreement provides, either expressly or bynecessary implication, which are to survive after the Expiry Date or terminationincluding those under Article 11 (Force Majeure), Article 13 (Events of Default andTermination), Article 14 (Liability and Indemnification), Article 16 (Governing Lawand Dispute Resolution), Article 17 (Miscellaneous Provisions), and other ArticlesandSchedulesofthisAgreementwhichexpresslyorbytheirnaturesurvive theTerm or termination of this Agreement shall continue and survive any expiry orterminationof thisAgreement.

### **2.5 Performance Bank Guarantee (PBG)**

- 2.5.1. ThePerformanceBankGuaranteefurnishedunderthisAgreementshallbeforguar anteeingthesuccessfulcommissioningofthe Project forpoweruptotheContractedCapacitywithinthe timespecified inthisAgreement.
- 2.5.2. The failure on the part of the SPG to furnish and maintain the Performance BankGuarantee shall be a material breach of the term of this Agreement on the part oftheSPG.
- 2.5.3. The PBG shall be initially valid from the date of issue until 2 months (i.e. sixty (60)days) beyond the 9 months from the date of signing of Power Purchase Agreement(PPA).
- 2.5.4. The PBG will be returned to the SPG after successful commissioning ofSolarpowerplant,aftertakingintoaccountanypenaltiesduetodelayincommiss ioningas pertermsandconditionsofRfS.
- 2.5.5. **CFA up to 100% of the total eligible CFA will be released to the RESCO developer through DISCOM on successful operation and performance of solar plant for two**

months after the commissioning with at least one month CUF as per minimum CUF agreed in PPA, as per MNRE's sanction for the CFA, subject to release of the same by MNRE-GoI

2.5.6. On

**ARTICLE3:CONDITIONSSUBSEQUENT**

- 3.1 The SPG agrees and undertakes to secure Project Financing Arrangements for its Project and should provide necessary documents to in this regard within six Months from the Date of issue of Work order by for the project.
- 3.2 The SPG shall identify the project land preferably within the distance of Five KM radius of the respective 66/11 KV Sub-station, get ownership of land or its lease rights and make necessary arrangement including ROW, clearances etc for the electrical line between 66/11 KV sub-station and the solar power plant. The SPG shall submit the final land documents within the period of 4 months after the date of signing of PPA or such other period as may be extended by DISCOM under Force Majeure provisions of Article 11 for the entire required land duly registered by appropriate revenue authority.

**ARTICLE4:CONSTRUCTION&DEVELOPMENTOFTHEPROJECT**

**4.1 SPG's Obligations**

- 4.1.1 The SPG undertake to be responsible, at SPG's own cost and risk, for:
- a) The SPG shall be solely responsible and make arrangements for infrastructure for development of the Project and for Connectivity with the 66/11 KV sub-station for confirming the evacuation of power by the Scheduled Commissioning date or COD, whichever is earlier, and all clearances related thereto;
  - b) obtaining all Consents, Clearances and Permits as required and maintaining all documents.
  - c) Designing, constructing, erecting, commissioning, completing and testing the Power Project including then RMS in accordance with the applicable Law, the Grid Code, the terms and conditions of this Agreement and Prudent Utility Practices.
  - d) the commencement of supply of power up to the Contracted Capacity to no later than the Scheduled Commissioning Date and continuance of the supply of power throughout the term of the Agreement at the agreed CUF;
  - e) Connecting the Power Project switchyard with the Interconnection Facilities at the Delivery Point. The SPG shall make adequate arrangements to connect the Power Project switchyard with the Interconnection Facilities at Interconnection / Metering / Delivery Point. SPG will be responsible for laying of dedicated 11KV line from Solar Power Plant to sub-station, construction of bay and related switchgear & metering equipment at sub-station where the plant is connected to the grid and metering is done. SPG will be

responsible to set up Remote Metering Systems as per Article 7.2 of this agreement

- f) owning the Power Project throughout the Term of Agreement free and clear of encumbrances, except those expressly permitted under Article 15;
- g) fulfilling all obligations undertaken by the SPG under this Agreement.
- h) The SPG shall be responsible for directly coordinating and dealing with, SLDC and GETCO and other authorities in all respects in regard to declaration of availability, scheduling and dispatch of Power and due compliance with deviation and settlement mechanism and the applicable Grid code/State Regulations.
- i) The SPG shall be required to follow the applicable rules regarding project registration with the State Nodal Agency GEDA in line with the provisions of the applicable policies/regulations of the State of Gujarat. It shall be the responsibility of the SPG to remain updated about the applicable charges payable to SLDC, GETCO, GEDA or any other authority under the respective rules, regulations, policies, framework.
- j) The technology adopted by SPG shall be in accordance with MNRE's Approved Models and Manufacturers of Solar PV Modules having Domestically manufactured PV Module. (Requirements for Compulsory Registration) Order, 2019 as amended from time to time
- k) All the mandatory standards issued by MNRE and / or BIS regarding project equipments and material shall be followed.
- l) The SPG shall be responsible for all payments on account of any taxes, cesses, duties or levies imposed by the GoG or its competent statutory authority on the land, equipment, material or works of the Project or on the Electricity generated or consumed by the Project or by itself or on the income or assets owned by it. All expenses including wheeling / transmission charges and losses, UI / DSM Charges applicable as per GERC / CERC Regulations, upto Delivery Point shall be paid by the SPG without any reimbursement by .
- m) To procure start up power required for the plant from .
- n) The SPG shall ensure that he shall not sell power to any other buyer except the under the agreement of this tender during the tenure of this PPA. At any point of time during the tenure of PPA, if it is found that the SPG has sold the solar power produce from the contracted solar plant strict legal action will be taken against the SPG, including stop deal or black list from Participation in future tender of MNRE in Gujarat and the SPG shall require to refund the proportionate CFA granted for the project by MNRE to .

For the recovery of the proportionate CFA, the CFA granted by MNRE for the project will be divided by 25 years to arrive at per year CFA. If

any event of sell of power is found at a particular time, the amount to be recovered from the SPG shall be the remaining period of PPA after the event date multiply by per year CFA.

The recovery of the proportionate CFA will be made through the payments of invoices or through remedies taken in accordance with applicable laws. In case of any liquidation of assets of the solar power plants prior to completion of PPA period the first charge shall be towards recovery of the proportionate CFA granted to the project by MNRE.

#### **4.2 Purchase and sale of Contracted Capacity**

4.2.1 Subject to the terms and conditions of this Agreement, the SPG undertakes to sell to and undertakes to pay Tariff for all the energy supplied at the Delivery Point corresponding to the Contracted Capacity.

#### **4.3 Right to Contracted Capacity & Energy**

4.3.1 , in any Contract Year shall not be obliged to purchase any additional energy from the SPG beyond the contract capacity. If for any Contract Year except for the first year of operation, it is found that the SPG has not been able to generate and supply minimum energy of \_\_\_\_\_ KWH (Units) (corresponding to 19% minimum CUF) for \_\_\_\_\_ Feeder level Solar plant during the term of the agreement, on account of reasons solely attributable to the SPG, then non-compliance by SPG shall make the SPG liable to pay the compensation. shall not be obliged to purchase energy in excess of maximum CUF of 30% during any contract year. If \_ decides to purchase the excess energy beyond CUF of 30%, the payments for such excess energy shall be made at 75% of the PPA tariff. For the first year of operation, the above limits shall be considered on pro-rata basis. The lower limit will, however be relaxable by to the extent of grid non-availability for evacuation which is beyond the control of the SPG.

4.3.2 This compensation shall be applied to the amount of shortfall in generation during the Contract Year. The amount of such penalty would ensure that the is offset for all potential costs associated with low generation and supply of power under the PPA. **The compensation payable to by the SPG shall be 25% (twenty-five percent) of the cost of this shortfall in energy terms, calculated at PPA tariff.** This compensation shall not be applicable in events of Force Majeure identified under PPA.

4.3.3 At any point of time block, the peak of capacity shall not reach higher than

the contracted capacity at the point where power is injected in the grid. The SPG shall forego the excess generation and reduce the output to the contract capacity and shall be required to pay the penalty/charges in case of failure to do so. The SPG shall install adequate protection equipment at the interconnection point to avoid excess energy feeding into the grid and failure to do so shall entitle DISCOM to not pay for the additional energy over and above the contracted capacity.

**4.4 Extension of Time**

4.4.1 In the event that the SPG is prevented from performing its obligations under Article 4.1 by the Scheduled Commissioning Date due to:

- (a) any DISCOM Event of Default; or
- (b) Force Majeure Events affecting, or
- (c) Force Majeure Events affecting the SPG,

the Scheduled Commissioning Date and the Expiry Date shall be deferred, subject to Article 4.4.4, for a reasonable period but not less than 'day for day' basis, to permit the SPG or DISCOM through the use of due diligence, to overcome the effects of the Force Majeure Events affecting the SPG or, or till such time such Event of Default is rectified by .

4.4.2 If the Parties have not agreed, within thirty (30) days after the affected Party's performance has ceased to be affected by the relevant circumstance, on the time period by which the Scheduled Commissioning Date or the Expiry Date should be deferred, any Party may raise the Dispute to be resolved in accordance with Article 16.

4.4.3 As a result of such extension, the newly determined Scheduled Commissioning Date and newly determined Expiry Date shall be deemed to be the Scheduled Commissioning Date and the Expiry Date for the purposes of this Agreement.

4.4.4 Notwithstanding anything to the contrary contained in this Agreement, any extension of the Scheduled Commissioning Date arising due to any reason envisaged in this Agreement shall not be allowed beyond the date pursuant to Article 4.5.2.

4.4.5 Delay in commissioning of the project beyond the scheduled commissioning date or reasons other than those specified in Article 4.4.1 shall be an event of default on part of the SPG and shall be subject to the consequences specified in the Article 4.5.

**4.5 Liquidated Damages not amounting to penalty for delay in Commissioning**

4.5.1 If the SPG is unable to commission the Project by the Scheduled Commissioning Date other than for the reasons specified in Article 4.4.1, the SPG shall pay to , damages for the delay in such commissioning and making the Contracted Capacity available for dispatch by the Scheduled

CommissioningDate asperfollowing:

- 4.5.2 In case any SPG fails to achieve this milestone, shall encash the PerformanceBankGuarantee(PBG)as liquidateddamages(LD)inthefollowing manner:

Delayuptotwomonths:LDequaltothePBGonperdaybasis.Theno.ofdaysin “month”forthe LD calculationshallbeconsidered as30.

Incasethecommissioningofthesolarpowerplantisdelayedovertwomonths:Thecomplete PBGamountshallbe encashedand DISCOM shall have right to terminate the PPA. The decision of MNRE regarding release of CFA shall be binding and to the account of SPG.

In case of delays of plant commissioning due to the reasons beyondthe control ofthe SPG, Procurer / after having been satisfied with documentary evidencesproduced by the SPG for the purpose, can extend the time for commissioning datewithout any financialimplicationsonthe SPG.

- 4.5.3The SPG further acknowledge that the amount of the liquidated damages fixed isgenuineandreasonablepre-estimateofthedamageshatmaybesufferedbyDISCOM.

#### **4.6 System Specifications and Quality Control**

- 4.6.1 All components used for installation of solar power plants shall confirm to applicable BIS/MNRE specifications and follow quality control guidelines issued by MNRE. **It will be mandatory to use domestically manufactured solar modules from ALMM only.**

- 4.6.2 Erection of 11 KV Line network shall be confirming to relevant standards .

#### **4.7 ThirdPartyVerification**

- 4.7.1 The SPG shall be further required to provide entry to the site of the Power Projectfree of all encumbrances at all times during the Term of the Agreement to andathirdPartynominatedby or anyIndianGovernmentalInstrumentalityforinspection and verification of the works being carried out by the SPG at the site ofthePowerProject.

- 4.7.2 The third party may verify the construction works/operation of the Power Projectbeing carried out by the SPG and if it is found that the construction works/operationofthePowerProjectisnotasperthePrudentUtilityPractices,itmayseekclarifications from SPG or require the works to be stopped or to comply with theinstructionsofsuchthirdparty.

#### **4.8 BreachofObligations**

- 4.8.1 The Parties herein agree that during the subsistence of this Agreement, subject to being in compliance of its obligations & undertakings under this Agreement, the SPG would have no right to negotiate or enter into any



dialogue with any third party for the sale of Contracted Capacity of power which is the subject matter of this Agreement. It is the specific understanding between the Parties that such bar will apply throughout the entire term of this Agreement.

**4.9 Generation compensation for Off-take constraints**

**4.9.1 Generation Compensation in offtake constraints due to Grid Unavailability:**

During the operation of the plant, shall endeavor to ensure 95% of grid availability

in a contract year, however, there can be some periods where the Project can generate power but due to temporary transmission unavailability, the power is not evacuated, for reasons not attributable to the SPG. In such cases, subject to

the submission of documentary evidences from the competent authority, the generation compensation shall be restricted to the following and there shall be no other claim, directly or indirectly against :

<b>Duration of Grid unavailability</b>	<b>Provision for Generation Compensation</b>
Grid unavailability in excess of 5% in a contract year as defined in the PPA (only period from 8am to 6pm to be counted):	<b><i>Generation Loss = [(Average Generation per hour during the Contract Year) × (number of hours of grid unavailability during the Contract Year)]</i></b> Where, Average Generation per hour during the Contract Year (kWh) = Total generation in the Contract Year (kWh) ÷ Total hours of generation in the Contract Year.

The excess generation beyond 19% CUF by the SPG equal to this generation loss shall be procured by at the PPA tariff so as to offset this loss in the succeeding 3 (three) Contract Years.

**4.9.2 Offtake constraints due to Backdown:** The SPG and shall follow the forecasting and

scheduling process as per the regulations in this regard by the Appropriate Commission. In the eventuality of backdown, subject to the submission of documentary evidences from the competent authority, the SPG shall be eligible for a minimum generation compensation, from , restricted to the following and there shall be no other claim, directly or indirectly against.

<b>Duration of Backdown</b>	<b>Provision for Generation Compensation</b>

<p>Hours of Backdown during a monthly billing cycle .</p>	<p><b>Minimum Generation Compensation = 100% of [(Average Generation per hour during the month) X (number of backdown hours during the month)] X PPA tariff</b></p> <p>Where, Average Generation per hour during the month (kWh) = Total generation in the month (kWh) ÷ Total hours of generation in the month</p>
---	---

The SPG shall not be eligible for any compensation in case the Backdown is on account of events like consideration of grid security or safety of any equipment or personnel or other such conditions. The Generation Compensation shall be paid as part of the energy bill for the successive month after JMR.

**ARTICLE 5: SYNCHRONISATION, COMMISSIONING AND COMMERCIAL OPERATION**

**5.1 Synchronization, Commissioning and Commercial Operation**

- 5.1.1 The SPG shall give at least thirty (30) days' advanced preliminary written notice and at least fifteen (15) days' advanced final written notice, of the date on which it intends to synchronize the Solar Power Project to the Grid System.
- 5.1.2 Subject to Article 5.1.1, the Power Project may be synchronized by the SPG to the Grid System when it meets all the connection conditions prescribed in applicable Grid Code then in effect and otherwise meets all other Indian legal requirements for synchronization to the Grid System.
- 5.1.3 The synchronization equipment and all necessary arrangements/equipment including RTU for scheduling of power generated from the Project and transmission of data to the concerned authority as per applicable regulation shall be installed by the SPG at its generation facility of the Power Project at its own cost. The SPG shall synchronize its system with the Grid System only after the approval of synchronization scheme is granted by the head of the concerned substation/ and checking/verification is made by the concerned authorities of the.
- 5.1.4 The SPG shall immediately after each synchronization/tripping of generator, inform the sub-station of the Grid System to which the Power Project is electrically connected in accordance with applicable Grid Code. In addition, the SPG will inject in-firm power to grid from time to time to carry out operational/ functional test prior to commercial operation. For avoidance of doubt, it is clarified that Synchronization

/ConnectivityoftheProjectwiththegridshallnottobeconsideredasCommissioningoftheProject.

- 5.1.5 The SPG shall commission the Project within nine (9) Months from the Date of execution of this PPA. Declaration of COD shall be certified by the commissioning committee.
- 5.1.6 The Parties agree that for the purpose of commencement of the supply of electricity by SPG to, liquidated damages for delay etc., the Scheduled Commissioning Date as defined in this Agreement shall be the relevant date.

## **ARTICLE 6: DISPATCH AND SCHEDULING**

### **6.1 Dispatch and Scheduling**

- 6.1.1 The SPG shall be required to schedule its power as per the applicable regulations of GERC / SLDC or any other competent agency and same being recognized by the SLDC or any other competent authority / agency as per applicable regulation / law / direction and maintain compliance to the applicable Codes / Grid Code requirements and directions, if any, as specified by concerned SLDC from time to time. Any deviation from the Schedule will attract the provisions of applicable regulation / guidelines / directions and any financial implication on account of this shall be on the account of the SPG.
- 6.1.2 The SPG shall be responsible for directly coordinating and dealing with the State Load Dispatch Centers, and other authorities in all respects in regard to declaration of availability, scheduling and dispatch of Power and due compliance with deviation and settlement mechanism and the applicable Grid Code Regulations.
- 6.1.3 The SPG shall be responsible for any deviation from scheduling and for any resultant liabilities on account of charges for deviation as per applicable regulations. UI/DSM charges on this account shall be directly paid by the SPG.
- 6.1.4 Auxiliary power consumption will be treated as per the orders of GERC or concerned GERC regulations. The charges for net import of energy by the solar power plant from the grid shall be billed at HTP-III tariff by . The SPG shall not undertake any other commercial activity within the project premises except generation of Solar Power under this contract.

## **ARTICLE 7: METERING**

### **7.1 Meters**

- 7.1.1 Metering and grid connectivity of the projects would be the responsibility of the SPG in accordance with the prevailing guidelines of , SLDC, GETCO and /

or CEA. and may facilitate in the process; however, the entire responsibility lies only with the SPG. The cost of required meters shall be borne by the SPG.

- 7.1.2 Meters and metering equipment shall be tested as per provision of GERC and as per IS 14697 at CPRI or any NABL accredited/distribution license lab before installation at site on the cost of SPG and should be properly sealed in the presence of designated authority from the time of installation.
- 7.1.3 The accuracy class, current rating and certifications of the metering system shall confirm with relevant CERC/ GERC Regulations, Grid Code and Central Electricity Authority (Installation and Operation of Meters) Regulations, 2006 as amended and revised from time to time.
- 7.1.4 SPG to install 3 ABT meters (main, check and standby) with RMS connectivity AND 2 CT-PT sets (one for main & check meter and another for standby meter) at substation end of the 33kV line. An indicative layout of metering arrangement is given below:

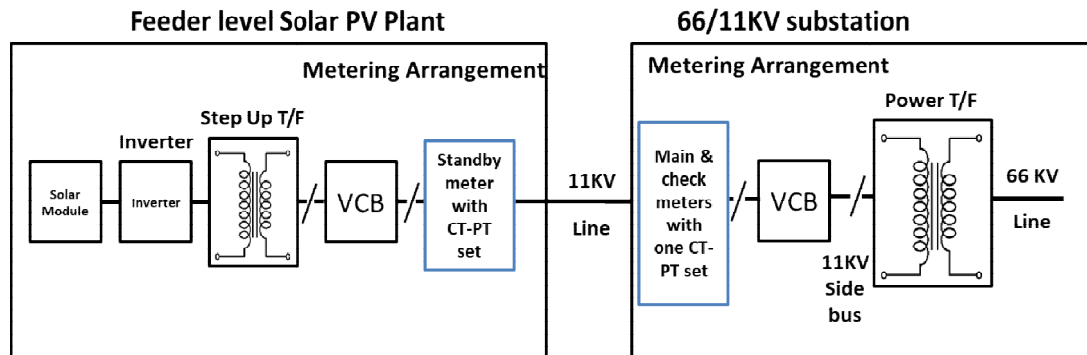

- 7.1.5 Installation and timely replacement of meters (main, check and standby) as required to directly measure energy supplied by the Solar Power Plant shall be the responsibility of selected bidder.
- 7.1.6 **SPG shall also be responsible for installation of IoT Devices-RMS Set for Remote Monitoring system connectivity of Inverters, String combiner box, Energy Meters at Solar plant and Substation.**
- 7.1.7 The cost of all required meters (main, check, standby meter at substation end along with consumer meters) and associated CT-PT sets shall be borne by the SPG.

## 7.2 Remote Monitoring System (RMS)

- 7.2.1 As per the MNRE guidelines for feeder level solarization under Component C of KUSUM scheme, it is mandatory for Discoms to monitor solar power generation and performance of the solar power plant through online system. The online data will be integrated with central monitoring portal of MNRE which will extract data from the State portals for monitoring of the scheme.

- 7.2.2 In line with MNRE model guidelines for State Level SEDM Software Development issued in July 2020, Gujarat Discoms are in the process of development of State Level Solar Energy Data Management (SEDM) platform to integrate & monitor the performance of all systems installed under Component A, B & C (individual as well as feeder level solarization) of PM-KUSUM scheme.
- 7.2.3 Also, as per the Specifications for Remote Monitoring System for Component A & C of the scheme, issued by MNRE on 15 Jul 2020, the SPG under this RfS shall be required to install required remote monitoring systems for solar power plant to integrate with State SEDM platform directly which in turn will have interface with National Level Solar Energy Data Management Platform of MNRE.
- 7.2.4 As part of National and State SEDM platform, various modules will be provided such as Scheme Progress Management, Asset Management, Live Asset Monitoring, Performance Analysis, Complaint and Ticket Management, Device Integration/SCADA Platform, Alarm/Events/Notification, Meter Data Acquisition (MDAS) / Meter Data Management (MDM), Archiving and Historian, Report Manager, SIA officer and EPC, Enterprise level user and role management.
- 7.2.5 MNRE and Discoms will develop and host the of National and State Level SEDM platform which is excluded from the scope of the SPG but SPG needs to operate and do various data entries for the portal for asset management and

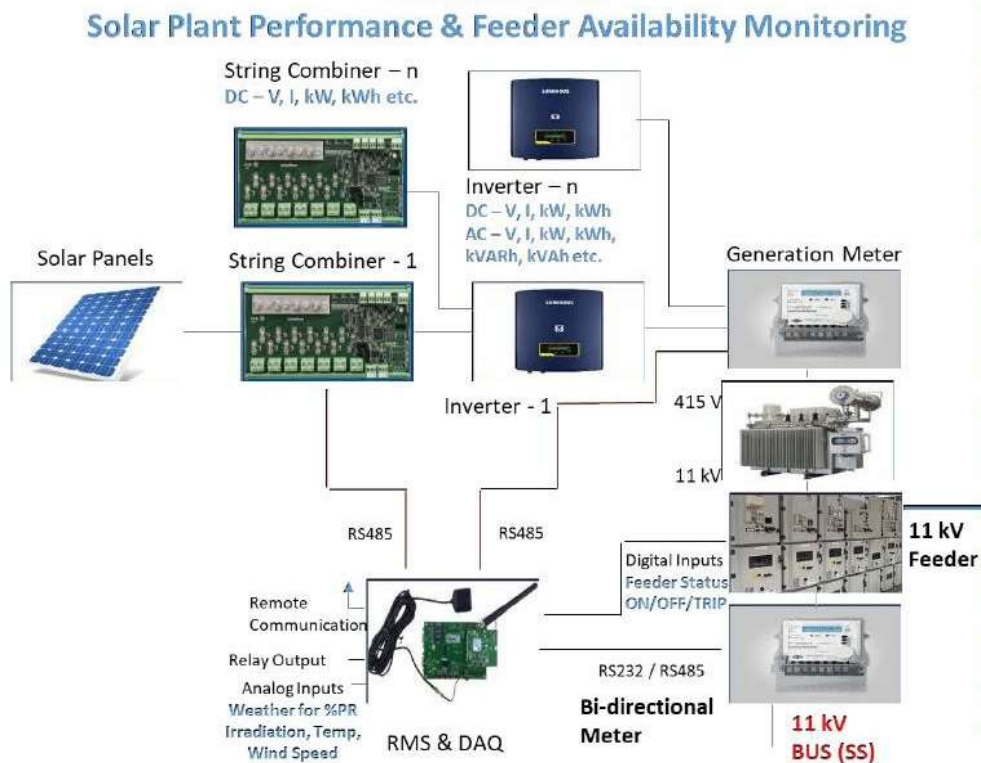

RMS.

7.2.6 As shown in above diagram SPG need to provide a remote monitoring system for:

(a) **Solar Power Plant Remote Monitoring system:** To capture electrical parameters from multiple devices such as ABT Meter, Generation Meter, Inverters, String Combiner boxes or String inverters. Remote monitoring system will capture important Electrical and Status parameters such as AC/DC voltage, control, power, energy as well as monitoring of Breaker etc and will transmit data to State Level Solar Energy data management (SEDM) platform. It shall be also possible to control Inverter Active and Reactive power.

(b) **Communication Connectivity for Solar Plant RMS and Smart Meter:**

- i. Field Device Connectivity: RMS will connect to Inverter, String combiner boxes or string inverters using RS485 MODBUS communication protocol as well as meters using RS232 DLMS protocol. Both protocols are widely used by equipment manufacturers.
- ii. Remote Connectivity: RMS will connect to State Level SEDM Server using 2G/3G/4G or any other suitable cellular communication.
- iii. Local Connectivity: Ethernet/Bluetooth/Wi-Fi connectivity to configure parameter, notifications, communication intervals, set points, operation mode configuration or to download locally stored data.

7.2.7 It is the responsibility of SPG to provide SIM card, recurring communication charges and maintain communication connectivity of more than 96% and data availability of 99% for the 25 years (unless extended by both the parties on mutual agreement) of operation & maintenance of solar power plant and its associated 11kV line.

**ARTICLE8:INSURANCES**

**8.1 Insurance**

8.1.1 The SPG shall effect and maintain or cause to be effected and maintained, at its own cost and expense, throughout the Term of PPA, Insurances against theft, damage, fire and damage or loss due to natural calamities, Cyclones, earthquake, flood, riots, etc. consistent with **Prudent Utility Practice** and all such risks to keep the Project in good condition and shall take Industrial All Risk insurance policy covering risks against any loss or damage, with such deductibles and with such endorsements and co-insured(s), which the Prudent Utility Practices would ordinarily merit maintenance of and as required under the Financing Agreements, and under the applicable laws.

**8.2 Application of Insurance Proceeds**

8.2.1 In case of the Project not being implemented through Financing Agreement(s), save as expressly provided in this Agreement or the Insurances, the proceeds of any insurance claim made due to loss or damage to the Power Project or any part of the Power Project shall be first applied to reinstatement, replacement or renewal of such loss or damage.

In case of the Project being financed through Financing Agreement(s), save as expressly provided in this Agreement or the Insurances, the proceeds of any insurance claim made due to loss or damage to the Power Project or any part of the Power Project shall be applied as per such Financing Agreements.

8.2.2 If a Force Majeure Event under the insurance contract renders the Power Project no longer economically and technically viable and the insurers under the Insurances make payment on a "total loss" or equivalent basis, shall have claim on such proceeds of such Insurance limited to outstanding dues of against SPG.

**8.3 Effect on liability of DISCOM**

8.3.1 Notwithstanding any liability or obligation that may arise under this Agreement, any loss, damage, liability, payment, obligation or expense which is insured or not or for which the SPG can claim compensation, under any Insurance shall not be charged to or payable by . It is for the SPG to ensure that appropriate insurance coverage is taken for payment by the insurer for the entire loss and there is no underinsurance or short adjustment etc.

**ARTICLE9:APPLICABLE TARIFF**

9.1 The SPG shall be entitled to receive the Tariff of ..... per kWh, fixed for the entire term of 25 years (unless extended by both the parties on mutual agreement), with effect from the COD, for the power sold to as reflected in the State Energy Accounts published by SLDC Guajrat.

## ARTICLE 10: BILLING AND PAYMENT

### 10.1.1 Energy measurement for Monthly billing

- a) The SPG shall raise the invoice after issuance of State Energy Account by SLDC each month and submit the relevant extracts thereof along with the monthly invoice.
- b) Subsequently, the SPG shall furnish the joint meter reading report (JMR)/Energy Account, duly verified by its authorized representative and concerned Executive Engineer, along with downloaded CMRI data (of all three meters) of 15 minutes time block to The Chief Engineer SLDC, Vadodara, through courier and/or e-mail along with the Monthly Bill (final energy net of import and export, multiplied by the Rs. per kWh tariff as per PPA and reactive power charges compensation) on the same day (i.e. 1st day of the month).
- c) Subsequently, the SPG shall furnish the joint meter reading report (JMR)/Energy Account, duly verified by its authorized representative and concerned Executive Engineer (O&M) Division, along with downloaded CMRI data (of all three meters) to The Chief Engineer (Proj), through courier and/or e-mail along with the Monthly Bill (final energy net of import and export, multiplied by the Rs. per kWh tariff as per PPA and reactive power charges or any other charges compensation) on the same day (i.e. 1st day of the month).
- d) Provided that:
  - i. if the date of commencement or supply of power falls during the period between the first (1<sup>st</sup>) day and up to and including the fifteenth (15<sup>th</sup>) day of a Month, the first Monthly Bill shall be issued for the period until the last day of such Month, or
  - ii. if the date of commencement of supply of power falls after the fifteenth (15<sup>th</sup>) day of a Month, the first Monthly Bill shall be issued for the period commencing from the Delivery Date until the last day of the immediately following Month.
- e) Provided further that if a Monthly Bill is received on or before the second (2<sup>nd</sup>) day of a Month, it shall be deemed to have been received on the second (2<sup>nd</sup>) Business Day of such Month.
- f) Provided further that if a Monthly Bill for the immediately preceding Month is issued after 1st day of the next Month, the Due Date for payment of such Monthly Bill shall be extended accordingly.
- g) The monthly bills shall be raised by SPG only after issuance of State Energy Account by SLDC.



### **10.1.2 Inspection and Testing of Meters**

- a) and SPG shall jointly inspect and if necessary, recalibrate the metering system on a regular basis but in any event, at least once every year or at a shorter interval at the request of any of the two parties.
- b) Each Meter comprising the metering system shall be sealed by , and shall be opened, tested or calibrated in the presence of both the parties.

### **10.1.3 Inaccuracy of Meters**

- a) In case the difference between the energy recorded in the main meter and the check meter for any calendar month is within 0.5%, the energy recorded in the main meters shall be taken as final.
- b) However, if the variation exceeds  $\pm 0.5\%$ , following steps shall be taken:
  - i. Both interface meters (Main as well Check) and metering system shall be tested and checked.
  - ii. Re-Calibration of both meters at site with reference standard meter of accuracy class higher than the meter under test, if no issues found in step (a) above.
  - iii. On carrying out the re-calibration of the main meter, if it is discovered that either the percentage of inaccuracy exceeds  $\pm 0.5\%$  or that the main meter is not working, the following procedure in order of priority, which ever is feasible, for arriving at the computation of quantity of energy during the period between the last calibration and the present, shall be followed:
    - On the basis energy recorded in the check meter if installed and functioned accurately; or
    - By correcting the error, if the percentage of error is ascertainable from calibration, tests or mathematical calculation
  - iv. The correction to the quantity of energy injected shall apply to the following periods (hereinafter referred to as the "Correction Period"):
    - To any period of time during which the main meter was known to be malfunctioning or to which the parties mutually agree;
    - If the period during which the main meter was malfunctioning is not known or is not agreed to between the parties, the correction shall be applicable for a period equal to half the time elapsed since the date of the preceding calibration test, provided that under no circumstances shall the Correction Period exceed one month.

- v. If the difference exist seven after such checking or testing, then the defective meter(s) shall be replaced with a tested meter.
- vi. In case of conspicuous failures like burning of meter and erratic display of metered parameters and when the error found in testing of meter is beyond the permissible limit of error provided in the relevant standard, the meters shall be immediately replaced with a tested meter.
- vii. In case where both the Main meter and Check meter fail, energy recorded in the Standby meter shall be considered as final and at least one of the meters shall be immediately replaced by a tested meter.

#### **10.1.4 General**

- a) From the Commercial Operations Date of the solar power plant, shall pay to the Successful SPG the monthly Tariff Payments subject to the adjustments as per provisions of the PPA and submission of following documents:
  - i. Monthly bill (Injection/Schedule at delivery point as certified by SLDC multiplied by the Rs. per kWh tariff as per PPA)
  - ii. Relevant Extracts of State Energy Account.
- b) All Tariff Payments shall be in Indian Rupees.
- c) The SPG shall be required to make arrangements and payments for import of energy (if any) as per applicable regulations.

**Reactive power charges** or any other charges as per CERC/GERC regulations shall be payable by SPG as per provisions of PPA.

#### **10.1.5 Delivery and Content of Monthly Bills/Supplementary Bills**

- a) The SPG shall issue to hard copy of a signed Monthly Bill for the immediately preceding Month based on the State Energy Account along with all relevant documents (payments made by selected bidder for drawl of power, payment of reactive energy charges, Metering charges or any other charges as per regulations of CERC/GERC shall not be a part of bill raised by SPG to )
- b) Each Monthly Bill shall include all charges as per the Agreement for the energy supplied for the relevant Month based on State Energy Account. The Monthly Bill amount shall be the product of the energy as per Energy Accounts and the applicable levelized tariff. Net energy import from the grid shall be billed at HTP-III tariff.

#### **10.1.6 Payment of Monthly Bills**

- a) On receipt of JMR/Energy Account along with CMRI data (of both meters) and bill, Superintending Engineer (Regulation) shall verify the readings and subsequent share the same along with original bill and other relevant document to .

shall make payment of the amounts due in Indian Rupees within thirty (30) days from the date of receipt of the Tariff Invoice by the Chief Engineer (Project) .

b) As defined under the PPA, "Due Date of Payment" in respect of a Tariff Invoice means the date, which is 30 (thirty) days from the date of receipt of such invoices by the designated official of the . The Tariff Invoice shall include relevant documents.

All payments required to be made under this Agreement shall also include any deduction or set off for:

- i. deductions required by the Law; and
- ii. Amount claimed by , if any, from the SPG, will be adjusted from the monthly energy payment.
- iii. Charges for net import of energy by the solar plant from the grid shall be as per HTP-III Tariff as per GERC

a) The SPG shall open a bank account (if not having any bank account) for all Tariff Payments to be made by to the SPG and notify of the details of such account at least sixty (60) Days before the dispatch of the first Monthly Bill.

#### **10.1.7 Late Payment Surcharge**

(1) For payment of Monthly bill by , if paid after Due Date of Payment, a late Payment charge shall be payable by to the SPG on the payment outstanding after the due date at the base rate of Late Payment Surcharge applicable for the period for the first month of default.

(2) The rate of Late Payment Surcharge for the successive months of default shall increase by 0.5 percent for every month of delay provided that the Late Payment Surcharge shall not be more than 3 percent higher than the base rate at any time.

(3) Provided that the rate at which Late Payment Surcharge shall be payable shall not exceed the rate of seven (7) percent in excess of the SBI 1 year Marginal Cost of Funds Based Lending Rate (MCLR) per annum / any replacement thereof by SBI, on the amount of outstanding payment, calculated on a week or part thereof basis viz. (SBI MCLR rate + 7%)

= \_\_\_\_\_ per week or part thereof.

52

(4) Provided further that all Payments shall be first adjusted towards Late Payment Surcharge and thereafter, towards monthly charges, starting from the longest overdue bill.

(5) The Late Payment Surcharge shall be claimed by SPG through the supplementary bill.

(6) The Late Payment Surcharge shall be governed as per the provisions of Electricity (Late Payment Surcharge) Rules, 2021 issued by Ministry of Power, Government of India vide notification dated 22.02.2021 and subsequent amendments or replacements thereof issued from time to time.

#### **10.1.8 Rebate**

a) For payment of any Bill on or before Due Date, the following Rebate shall be paid by the SPG to in the following manner and the SPG shall not raise

any objection to the payments made under this article.

- i. For payment of Monthly Bill by , if paid before Due Date of Payment, a Rebate shall be deducted by at the rate of seven (7) percent in excess of the applicable SBI 1 year Marginal Cost of Funds Based Lending Rate (MCLR) per annum / any replacement thereof by SBI, on the amount paid before due date, calculated on a week or part thereof basis viz.

(SBI MCLR rate + 7%)

= \_\_\_\_\_ per week or part thereof.

52

**10.1.9 Payment of Supplementary Bills**

- a) Either \_\_\_\_\_ party may raise a ("Supplementary Bill") for payment on account of adjustments required by the Energy Accounts (if any) and such Supplementary Bill shall be paid by the other Party.
- b) The Parties shall remit all amounts due under a Supplementary Bill to the Designated Account by the Due Date.
- c) The Rebate and Late Payment Surcharge shall be applicable at the same terms applicable to the Monthly Bill.

**10.1.10 Payment Security Mechanism**

**Letter of Credit (LC):**

- a) shall provide to the SPG, in respect of payment of its Monthly Bills and/or Supplementary Bills, a monthly unconditional, revolving and irrevocable letter of credit ("Letter of Credit"), opened and maintained which may be drawn upon by the SPG in accordance with the PPA.
- b) Not later than one (1) Month before the start of supply, through a scheduled bank open a Letter of Credit in favour of the SPG, to be made operative from a date prior to the Due Date of its first Monthly Bill under this Agreement. The Letter of Credit shall have a term of twelve (12) Months and shall be renewed annually, for an amount equal to:
  - i. for the first Contract Year, equal to the estimated average monthly billing;
  - ii. for each subsequent Contract Year, equal to the average of the monthly billing of the previous Contract Year.
- c) Provided that the SPG shall not draw upon such Letter of Credit prior to the Due Date of the relevant Monthly Bill and/or Supplementary Bill, and shall not make more than one drawal in a Month.
- d) Provided further that if at any time, such Letter of Credit amount falls short of the amount specified above due to any reason whatsoever, shall restore such shortfall within fifteen (15) days.
- e) shall cause the scheduled bank issuing the Letter of Credit to intimate the SPG, in writing regarding establishing of such irrevocable Letter of Credit.

- f) shall ensure that the Letter of Credit shall be renewed not later than its expiry.
- g) All costs relating to opening, maintenance of the Letter of Credit shall be borne by the SPG.
- h) If fails to pay undisputed Monthly Bill or Supplementary Bill or a part thereof within and including the Due Date, then, subject to above, the SPG may draw upon the Letter of Credit, and accordingly the bank shall pay without any reference or instructions from , an amount equal to such Monthly Bill or Supplementary Bill or part thereof, in accordance with above, by presenting to the scheduled bank issuing the Letter of Credit, the following documents:
  - i. a copy of the Monthly Bill or Supplementary Bill which has remained unpaid to SPG and;
  - ii. a certificate from the SPG to the effect that the bill at item (a) above, or specified part thereof, is in accordance with the Agreement, is not disputed and has remained unpaid beyond the Due Date;

#### **10.1.11 Disputed Bill**

- a) If does not dispute a Monthly Bill or a Supplementary Bill raised by the SPG within thirty (30) days of receiving such Bill shall be taken as conclusive.
- b) If disputes the amount payable under a Monthly Bill or a Supplementary Bill, as the case may be, it shall pay undisputed amount of the invoice amount and it shall within fifteen 30 days of receiving such Bill, issue a notice (the "Bill Dispute Notice") to the invoicing Party setting out:
  - i. the details of the disputed amount;
  - ii. its estimate of what the correct amount should be; and
  - iii. all written material in support of its claim.
- c) If the SPG agrees to the claim raised in the Bill Dispute Notice, the SPG shall revise such Bill and present along with the next Monthly Bill. In such a case excess amount shall be refunded along with interest at the same rate as Late Payment Surcharge, which shall be applied from the date on which such excess payment was made by the disputing Party to the invoicing Party and up to and including the date on which such payment has been received as refund.
- d) If the SPG does not agree to the claim raised in the Bill Dispute Notice, it shall, within fifteen (15) days of receiving the Bill Dispute Notice, furnish a notice (Bill Disagreement Notice) to (i.e. office of Superintending Engineer (Regulation)), providing:
  - i. reasons for its disagreement;
  - ii. its estimate of what the correct amount should be; and
  - iii. all written material in support of its counterclaim.
- e) Upon receipt of the Bill Disagreement Notice by Superintending Engineer (Regulation), , authorized representative(s) or a director of the board of directors/

member of board of the and SPG shall meet and make best endeavours to amicably resolve such dispute within fifteen (15) days of receipt of the Bill Disagreement Notice.

- f) If the Parties do not amicably resolve the Dispute within fifteen (15) days of receipt of Bill Disagreement Notice, the matter shall be referred to Dispute resolution in accordance with Article 16 of PPA.
- g) For the avoidance of doubt, it is clarified that despite a Dispute regarding an invoice, shall, without prejudice to its right to Dispute, be under an obligation to make payment of undisputed amount of the invoice amount in the Monthly Bill.

## **ARTICLE 11: FORCE MAJEURE**

### **11.1 Definitions**

11.1.1 In this Article, the following terms shall have the following meanings:

### **11.2 Affected Party**

11.2.1 An affected Party means DISCOM or the SPG whose performance has been affected by an event of Force Majeure.

### **11.3 Force Majeure Events**

- a) Neither Party shall be responsible or liable for or deemed in breach hereof because of any delay or failure in the performance of its obligations hereunder (except for obligations to pay money due prior to occurrence of Force Majeure events under this Agreement) or failure to meet milestone dates due to any event or circumstance (a "Force Majeure Event") beyond the reasonable control of the Party experiencing such delay or failure, including the occurrence of any of the following:
  - i) acts of God;
  - ii) typhoons, floods, lightning, cyclone, hurricane, drought, famine, epidemic, plague or other natural calamities;
  - iii) acts of war (whether declared or undeclared), invasion or civil unrest;
  - iv) any requirement, action or omission to act pursuant to any judgment or order of any court or judicial authority in India (provided such requirement, action or omission to act is not due to the breach by the SPG or of any Law or any of their respective obligations under this Agreement);
  - v) inability despite complying with all legal requirements to obtain, renew or maintain required licenses or Legal Approvals;
  - vi) earthquakes, explosions, accidents, landslides; fire;
  - vii) expropriation and/or compulsory acquisition of the Project in whole or in part by Government Instrumentality;
  - viii) chemical or radioactive contamination or ionizing radiation; or

- ix) damage to or breakdown of transmission facilities of GETCO/ DISCOMs;
- x) Exceptionally adverse weather condition which are in excess of the statistical measure of the last hundred (100) years.

#### **11.4 Force Majeure Exclusions**

- a) Force Majeure shall not include the following conditions, except to the extent that they are consequences of an event of Force Majeure:
  - 1. Unavailability, Late Delivery or Change in cost of plants and machineries, equipment, materials, spares parts or consumables for the project;
  - 2. Delay in performance of any contractor / sub contractor or their agents;
  - 3. Non performance resulting from normal wear and tear experience in power generation materials and equipment;
  - 4. Strike or Labour Disturbances at the facilities of affected parties;
  - 5. Insufficiency of finances or funds or the agreement becoming onerous to perform, and
  - 6. Non performance caused by, or concerned with, the affected party's
    - I. Negligent and intentional acts, errors or omissions;
    - II. Failure to comply with Indian law or Indian Directive; or
    - III. Breach of, or default under this agreement or any Project agreement or Government agreement.
- b) The affected Party shall give notice to other party of any event of Force Majeure as soon as reasonably practicable, but not later than 7 days after the date on which such Party knew or should reasonably have known of the commencement of the event of Force Majeure. If any event of Force Majeure results in a breakdown of communication rendering it not reasonable to give notice within the applicable time limit specified herein, then the party claiming Force Majeure shall give notice as soon as reasonably practicable after reinstatement of communication, but not later than one day after such reinstatement. Such notice shall include full particulars of the event of Force Majeure, its effects on the Party claiming relief and the remedial measures proposed, and the Affected Party shall give the other Party regular (and not less than monthly) reports on the progress of those remedial measures and such other information as the other party may reasonably request about the situation.
- c) The affected Party shall give notice to the other Party of (1) cessation of relevant event of Force Majeure; and (2) cessation of the effects of such event of Force Majeure on the performance of its rights or obligations under

this agreement, as soon as practicable after becoming aware of each of these cessations.

- d) To the extent not prevented by a Force Majeure event, the affected party shall continue to perform its obligations pursuant to this agreement. The affected party shall use its reasonable efforts to mitigate the effect of any event of Force Majeure as soon as practicable.

### **11.5 AvailableReliefforaForceMajeureEvent**

No Party shall be in breach of its obligations pursuant to this agreement to the extent that the performance of its obligations was prevented, hindered or delayed due to a Force Majeure event. However, adjustment in tariff shall not be allowed on account of Force Majeure event.

For avoidance of doubt, neither Party's obligation to make payments of money due and payable prior to occurrence of Force Majeure events under this Agreement shall be suspended or excused due to the occurrence of a Force Majeure Event in respect of such Party.

## **ARTICLE12:CHANGEINLAW**

### **12.1 Definitions**

**"Change in Law" shall refer to the occurrence of any of the following events notified after the Bid Deadline.**

- a) the enactment, bringing into effect, adoption, promulgation, amendment, modification or repeal, of any statute, decree, ordinance or other law, regulations, notice, circular, code, rule or direction by Governmental Instrumentality or a change in its interpretation by a Competent Court of law, tribunal, government or statutory authority or any of the above regulations, taxes, duties charges, levies etc. that results in any change with respect to any tax or surcharge or cess levied or similar charges by the Competent Government on the generation of electricity (leviable on the final output in the form of energy) or sale of electricity.
- b) Introduction / modification / changes in rates of safeguard duty and/or anti-dumping duty and/or custom duty including surcharge thereon which have direct effect on the cost of solar PV modules.

### **12.2 ReliefforChange in Law**

- a) In case Change in Law on account of 9.1.1 (a) above results in the SPG's costs directly attributable to the Project being decreased or increased by one percent (1%), of the estimated revenue from the Electricity for the Contract Year for which such adjustment becomes applicable or more, during Operation Period, the Tariff Payment to the SPG shall be appropriately increased or decreased with due approval of GERC.
- b) In case of Change in Law on account of 9.1.1 (b) above, the SPG shall be allowed an increase / decrease in tariff of 1 paise / unit for every increase / decrease of



Rs. 2 Lakh per MW in the Project Cost incurred upto the Scheduled Commercial Operation Date upon submission of proof of payment made by the SPG towards safeguard duty and/or anti-dumping duty and/or custom duty to the concerned Authority and with due approval of GERC. This increase / decrease in tariff due to this change in cost of solar PV modules shall be limited to actual DC capacity or 150% (One hundred & fifty percent) of contracted AC capacity, whichever is lower.

- c) or SPG, as the case may be, shall provide the other Party with a certificate stating that the adjustment in the Tariff Payment is directly as a result of the Change in Law and shall provide supporting documents to substantiate the same and such certificate shall correctly reflect the increase or decrease in costs.
- d) The revised tariff shall be effective from the date of such Change in Law as approved by GERC.

### **ARTICLE 13: EVENTS OF DEFAULT AND TERMINATION**

#### **13.1 SPG Event of Default**

13.1.1 The occurrence and/or continuation of any of the following events, unless any such event occurs as a result of a Force Majeure Event or a breach by DISCOM of its obligations under this Agreement, shall constitute an SPG Event of Default:

- (i) the failure to commence supply of power to DISCOM up to the Contracted Capacity, by the end of the period specified in Article 4, or failure to continue supply of Contracted Capacity to DISCOM after Commercial Operation Date throughout the term of this Agreement, or

if

- the SPG assigns, mortgages or charges or purports to assign, mortgage or charge any of its assets or rights related to the Power Project in contravention of the provisions of this Agreement; or
- the SPG transfers or novates any of its rights and/ or obligations under this agreement, in a manner contrary to the provisions of this Agreement; except where such transfer
- is in pursuance of a Law; and does not affect the ability of the transferee to perform, and such transferee has the financial capability to perform, its obligations under this Agreement or
- is to a transferee who assumes such obligations under this Agreement and the Agreement remains effective with respect to the transferee;

if

- a. the SPG becomes voluntarily or involuntarily the subject of any bankruptcy or insolvency or winding up proceedings and such proceedings remain uncontested for a period of thirty (30) days, or
- b. any winding up or bankruptcy or insolvency order is passed against the SPG, or

- c. the SPG goes into liquidation or dissolution or has a receiver or any similar officer appointed over all or substantially all of its assets or official liquidator is appointed to manage its affairs, pursuant to Law, provided that a dissolution or liquidation of the SPG will not be a SPG Event of Default if such dissolution or liquidation is for the purpose of a merger, consolidation or reorganization and where the resulting company retains creditworthiness similar to the SPG and expressly assumes all obligations of the SPG under this Agreement and is in a position to perform them; or
- (ii) the SPG repudiates this Agreement and does not rectify such breach within a period of thirty (30) days from a notice from DISCOM in this regard; or
- (iii) except where due to any DISCOM's failure to comply with its material obligations, the SPG is in breach of any of its material obligations pursuant to this Agreement, and such material breach is not rectified by the SPG within thirty (30) days of receipt of first notice in this regard given by DISCOM.
- (iv) Occurrence of any other event which is specified in this agreement to be a material breach/default of the SPG
- (v) except where due to any DISCOM's failure to comply with its material obligations, the SPG is in breach of any of its material obligations pursuant to this Agreement, and such material breach is not rectified by the SPG within thirty (30) days of receipt of first notice in this regard given by DISCOM.
- (vi) Failure on the part of the SPG for a continuous period of ninety (90) days to (i) operate and/or (ii) maintain (in accordance with Prudent Utility Practices), the Project at all times.
- (vii) Failure on part of the SPG to maintain the minimum shareholding of 51% for a period of one year after Commercial Operation Date of the Project.
- (viii) Failure to supply power in terms of the PPA
- (ix) Failure to make any payment required to be made to DISCOM under this agreement within three (3) months after the due date of a valid invoice raised by the DISCOM on the SPG.

### **13.2 DISCOM Event of Default**

13.2.1 The occurrence and the continuation of any of the following events, unless any such event occurs as a result of a Force Majeure Event or a breach by the SPG of its obligations under this Agreement, shall constitute the Event of Default on the part of the faulting DISCOM:

- (i) DISCOM fails to pay (with respect to a Monthly Bill or a Supplementary Bill), subject to Article 11, for a period of ninety (90) days after the Due Date and the SPG is unable to recover the amount outstanding to the SPG through the Letter of Credit,

- (ii) DISCOM repudiates this Agreement and does not rectify such breach even within a period of sixty (60) days from a notice from the SPG in this regard; or
- (iii) If DISCOM becomes voluntarily or involuntarily the subject of proceeding under any bankruptcy or insolvency laws or goes into liquidation or dissolution or has a receiver appointed over it or liquidator is appointed, pursuant to Law, except where such dissolution of DISCOM is for the purpose of a merger, consolidation or reorganization and where the resulting entity has the financial standing to perform its obligations under this Agreement and creditworthiness similar to DISCOM and expressly assumes all obligations under this agreement and is in a position to perform them.

### **13.3 Procedure for cases of SPG Event of Default**

- 13.3.1 Upon the occurrence and continuation of any SPG Event of Default under Article 13.1, DISCOM shall have the right to deliver to the SPG, with a copy to the representative of the lenders to the SPG with whom the SPG has executed the Financing Agreements, a notice stating its intention to terminate this Agreement (DISCOM Preliminary Default Notice), which shall specify in reasonable detail, the circumstances giving rise to the issue of such notice and calling upon the SPG to remedy the same. Where a "Default Notice" has been issued with respect to an Event of Default, which requires the co-operation of both DISCOM and the SPG to remedy, DISCOM shall render all reasonable co-operation to enable the Event of Default to be remedied without any legal obligations. Upon being in default on account of failure to commission the project within Scheduled Commercial Operation Date, the SPG shall be liable to pay liquidated damages as per Article 4.5 whereas for failure to supply power in terms of Article 4.3, the SPG shall be liable to make payment of compensation as per the said clause. For other cases, the damages shall be as under.
- a. At the expiry of 90 (ninety) days from the delivery of the default notice and unless the Parties have agreed otherwise, or the Event of Default giving rise to the default notice has been remedied, the SPG shall have liability to make payment toward compensation to DISCOM equivalent to six (6) months' billing at minimum CUF for its contracted capacity. Also, DISCOM shall have the right to recover the said damages by way of forfeiture of bank guarantee, if any, without prejudice to resorting to any other legal course or remedy.
  - b. In addition to the levy of damages as aforesaid, in the event of a default by the SPG, the lenders shall be entitled to exercise their rights to seek substitution of the SPG by a selectee, in accordance with the substitution agreement and in concurrence with DISCOM. However, in the event the lenders are unable to substitute the defaulting SPG within the stipulated period, DISCOM may terminate the PPA and acquire the Project assets for an amount equivalent to 90% of the debt due by issuing a "Termination Notice" /

“Takeover Notice”, failing which, the lenders may exercise their mortgage rights and liquidate the Project assets.

- c. Provided that any substitution under this Agreement can only be made with the condition that the selectee meets the eligibility requirements of Request for Selection (RfS) issued by DISCOM.
- d. The lenders in concurrence with DISCOM, may seek to exercise the right of substitution under by an amendment or novation of the PPA in favour of the selectee. The SPG shall cooperate with DISCOM to carry out such substitution and shall have the duty and obligation to continue to operate the Power Project in accordance with this PPA till such time as the substitution is finalized. In the event of Change in Shareholding/Substitution of Promoters triggered by the Financial Institutions leading to signing of fresh PPA with a New Entity, an amount of Rs. 10 Lakh per Project per Transaction as Facilitation Fee (non-refundable) shall be deposited by the developer-SPG to DISCOM.

13.3.2 During the Consultation Period, the Parties shall continue to perform their respective obligations under this Agreement.

#### **13.4 Procedure for cases of DISCOM Event of Default**

13.4.1 Upon the occurrence and continuation of any DISCOM Event of Default specified in Article 13.2, the SPG shall have the right to deliver to DISCOM, a SPG Preliminary Default Notice, which notice shall specify in reasonable detail the circumstances giving rise to its issue and calling upon DISCOM to remedy the same.

13.4.2 DISCOM with the prior consent of the SPG may novate its part of the PPA to any third party, including its Affiliates within the period of 7 days following the expiry of notice period. In the event the aforesaid novation is not acceptable to the SPG, or if no offer of novation is made by the defaulting Procurer/ DISCOM within the stipulated period of 7 days, then the SPG may terminate the PPA and at its discretion require the defaulting Procurer/ DISCOM to either (i) takeover the Project assets by making a payment of the termination compensation equivalent to the amount of the debt due and 110% (one hundred and ten per cent) of the adjusted equity as detailed below, less insurance cover, if any by issuing a “Termination Notice” / “Takeover Notice”, or, (ii) pay to the SPG, damages, equivalent to 6 (six) months billing at contracted CUF, or balance PPA period whichever is less, of charges for its contracted capacity, with the Project assets being retained by the SPG.

13.4.3 In the event of such termination of PPA, any damages or charges payable to GETCO/ DISCOM, for the connectivity of the plant, shall be borne by DISCOM.

13.4.4 “Adjusted Equity” means the Equity funded in Indian Rupees and adjusted on the first day of the current month (the “Reference Date”), in the manner set forth

below, to reflect the change in its value on account of depreciation and variations in Wholesale Price Index (WPI), and for any Reference Date occurring between the first day of the month of Appointed Date (the date of achievement of Financial Closure) and the Reference Date;

i. On or before Commercial Operation Date (COD), the Adjusted Equity shall be a sum equal to the Equity funded in Indian Rupees and expended on the Project, revised to the extent of one half of the variation in WPI occurring between the first day of the month of Appointed Date and Reference Date;

ii. An amount equal to the Adjusted Equity as on COD shall be deemed to be the base (the "Base Adjusted Equity");

iii. After COD, the Adjusted Equity hereunder shall be a sum equal to the Base Adjusted Equity, reduced by 0.333% (zero point three threethree percent) thereof at the commencement of each month following the COD [reduction of 1% (one percent) per quarter of an year] and the amount so arrived at shall be revised to the extent of variation in WPI occurring between the COD and the Reference Date;

For the avoidance of doubt, the Adjusted Equity shall, in the event of termination, be computed as on the Reference Date immediately preceding the Transfer Date; provided that no reduction in the Adjusted Equity shall be made for a period equal to the duration, if any, for which the PPA period is extended, but the revision on account of WPI shall continue to be made.

13.4.5 "Debt Due" means the aggregate of the following sums expressed in Indian Rupees outstanding on the Transfer Date:

i. The principal amount of the debt provided by the Senior Lenders under the Financing Agreements for financing the Total Project Cost (the 'Principal') but excluding any part of the principal that had fallen due for repayment 2 (two) years prior to the Transfer Date;

ii. All accrued interest, financing fees and charges payable under the Financing Agreements on, or in respect of, the debt referred to in sub-clause (i) above until the Transfer Date but excluding: (i) any interest, fees or charges that had fallen due one year prior to the Transfer Date, (ii) any penal interest or charges payable under the Financing Agreements to any Senior Lender, (iii) any pre-payment charges in relation to accelerated repayment of debt except where such charges have arisen due to Utility Default, and (iv) any Subordinated Debt which is included in the Financial Package and disbursed by lenders for financing the Total Project Cost. Provided that if all or any part of the Debt Due is convertible into Equity at the option of Senior Lenders and/or the Concessionaire, it shall for the purposes of this Agreement be deemed not to be Debt Due even if no such conversion has taken place and the principal thereof shall be dealt with as if such

conversion had been undertaken. Provided further that the Debt Due, on or after COD, shall in no case exceed 80% (eighty percent) of the Total Project Cost.”

13.4.6 During the Consultation Period, the Parties shall continue to perform their respective obligations under this Agreement.

13.4.7 After a period of two hundred ten (210) days following the expiry of the Consultation Period and unless the Parties shall have otherwise agreed to the contrary or DISCOM Event of Default giving rise to the Consultation Period shall have ceased to exist or shall have been remedied, DISCOM under intimation to SPG shall, subject to the prior consent of the SPG, novate its part of the PPA to any third party, including its Affiliates within the stipulated period. In the event the aforesaid novation is not acceptable to the SPG, or if no offer of novation is made by DISCOM within the stipulated period, then the SPG may terminate the PPA and at its discretion require DISCOM to either (i) take over the Project assets by making a payment of the termination compensation equivalent to the amount of the debt due and 110% (one hundred and fifty per cent) of the adjusted equity or, (ii) pay to the SPG, damages, equivalent to 6 (six) months, or balance PPA period whichever is less, of charges for its contracted capacity, with the Project assets being retained by the SPG.

Provided further that at the end of three (3) month period from the period mentioned in this Article 13.4.4, this Agreement may be terminated by the SPG.

## **ARTICLE 14: LIABILITY AND INDEMNIFICATION**

### **14.1 Indemnity**

14.1.1 **The SPG's indemnity** - The SPG agrees to defend, indemnify and hold harmless DISCOM, its officers, directors, agents, employees and affiliates (and their respective officers, directors, agents and employees) from and against any and all claims, liabilities, actions, demands, judgments, losses, costs, expenses, suits, actions and damages arising by reason of bodily injury, death or damage to property sustained by third parties that are caused by an act of negligence or the willful misconduct of the SPG, or by an officer, director, sub-contractor, agent or employee of the SPG except to the extent of such injury, death or damage as is attributable to the willful misconduct or negligence of, or breach of this Agreement by, DISCOM, or by an officer, director, sub-contractor, agent or employee of the DISCOM.

14.1.2 **DISCOM's Indemnity** - DISCOM agrees to defend, indemnify and hold harmless the SPG, its officers, directors, agents, employees and affiliates (and their respective officers, directors, agents and employees) from and against any and all claims, liabilities, actions, demands, judgments, losses, costs, expenses, suits, actions and damages arising by reason of bodily injury, death or damage to property sustained by third parties that are caused by an act of negligence or the willful misconduct of DISCOM, or by an officer, director, sub-contractor, agent or employee of DISCOM except to the extent of such injury, death or damage as is attributable to the willful misconduct or negligence of, or breach of this Agreement by, the

SPG, or by an officer, director, sub-contractor, agent or employee of the SPG.

## **ARTICLE 15: ASSIGNMENTS AND CHARGES**

### **15.1 Assignments**

- 15.1.3 Neither Party shall assign this Agreement nor shall any portion hereof without the prior written consent of the other Party, provided further that any assignee expressly assume the assignor's obligations thereafter arising under this Agreement pursuant to documentation satisfactory to such other Party. However, such assignment shall be permissible only for entire contracted capacity.
- 15.1.3 Provided however, no approval is required from DISCOM for the assignment by the SPG of its rights herein to the Financing Parties and their successors and assigns in connection with any financing or refinancing related to the construction, operation and maintenance of the Project.
- 15.1.3 In furtherance of the foregoing, DISCOM acknowledges that the Financing Documents may provide that upon an event of default by the SPG under the Financing Documents, the Financing Parties may cause the SPG to assign to a third party the interests, rights and obligations of the SPG thereafter arising under this Agreement. DISCOM further acknowledges that the Financing Parties, may, in addition to the exercise of their rights as set forth in this Section, cause the SPG to sell or lease the Project and cause any new lessee or purchaser of the Project to assume all of the interests, rights and obligations of the SPG thereafter arising under this Agreement.

### **15.2 Permitted Charges**

- 15.2.1 SPG shall not create or permit to subsist any encumbrance over all or any of its rights and benefits under this Agreement, other than as set forth in Article 15.1

## **ARTICLE 16: GOVERNING LAW AND DISPUTE RESOLUTION**

### **16.1 Governing Law**

- 16.1.1 This Agreement shall be governed by and construed in accordance with the Electricity Act 2003 and other applicable Laws of India. Any legal proceedings in respect of any matters, claims or disputes under this Agreement shall be under the jurisdiction of Gujarat Electricity Regulatory Commission.

### **16.2 Dispute Resolution**

- 16.2.1 All disputes or differences between the Parties arising out of or in connection with this Agreement shall be first tried to be settled through mutual negotiation.
- 16.2.2 The Parties hereto agree to attempt to resolve all disputes arising hereunder promptly, equitably and in good faith.
- 16.2.3 Each Party shall designate in writing and communicate to the other Party its own representative who shall be authorized to resolve any dispute arising under this

Agreement in an equitable manner and, unless otherwise expressly provided herein, to exercise the authority of the Parties hereto to make decisions by mutual agreement.

16.2.4 In the event that such differences or disputes between the Parties are not settled through mutual negotiations within sixty (60) days, after such dispute arises, then it shall be adjudicated by GERC in accordance with the law.

**ARTICLE 17: MISCELLANEOUS PROVISIONS**

**17.1 Amendment**

17.1.1 This Agreement shall not be amended, changed, altered, or modified except by a written instrument duly executed by an authorized representative of both Parties. However, DISCOM may consider any amendment or change that the Lenders may require to be made to this Agreement.

**17.2 Waiver**

17.2.1 Any failure on the part of a Party to exercise, and any delay in exercising, exceeding three years, any right hereunder shall operate as a waiver thereof. No waiver by a Party of any right hereunder with respect to any matter or default arising in connection with this Agreement shall be considered a waiver with respect to any subsequent matter or default.

**17.3 Severability**

17.3.1 The invalidity or unenforceability, for any reason, of any part of this Agreement shall not prejudice or affect the validity or enforceability of the remainder of this Agreement, unless the part held invalid or unenforceable is fundamental to this Agreement.

**17.4 Notices**

17.4.1 Any notice, communication, demand, or request required or authorized by this Agreement shall be in writing and shall be deemed properly given upon date of receipt if delivered by hand or sent by courier, if mailed by registered or certified mail at the time of posting, if sent by fax when dispatched (provided if the sender's transmission report shows the entire fax to have been received by the recipient and only if the transmission was received in legible form), to:

**In case of SPG**

Name & Designation	
Address	

Email	
Mobile/Whatsapp No.	
Telephone	

**In case of DISCOM**



Name & Designation	
Address	
Email	
Telephone	

**17.5 Language**

- 17.5.1 All agreements, correspondence and communications between the Parties relating to this Agreement and all other documentation to be prepared and supplied under the Agreement shall be written in English, and the Agreement shall be construed and interpreted in accordance with English language.
- 17.5.2 If any of the agreements, correspondence, communications or documents are prepared in any language other than English, the English translation of such agreements, correspondence, communications or documents shall prevail in matters of interpretation.

**17.6 Restriction of Shareholders/Owners' Liability**

- 17.6.1 Parties expressly agree and acknowledge that none of the shareholders of the Parties hereto shall be liable to the other Parties for any of the contractual obligations of the concerned Party under this Agreement. Further, the financial liabilities of the shareholder/s of each Party to this Agreement, shall be restricted to the extent provided in the Indian Companies Act, 2013.

**17.7 Taxes and Duties**

- 17.7.1 The SPG shall bear and promptly pay all statutory taxes, duties, levies and cess, assessed/levied on the SPG, contractors or their employees that are required to be paid by the SPG as per the Law in relation to the execution of the Agreement and for supplying power as per the terms of this Agreement.
- 17.7.2 DISCOM shall be indemnified and held harmless by the SPG against any claims that may be made against DISCOM in relation to the matters set out in Article 17.9.1.
- 17.7.3 DISCOM shall not be liable for any payment of, taxes, duties, levies, cess whatsoever for discharging any obligation of the SPG by DISCOM on behalf of SPG.

**17.8 Independent Entity**

- 17.8.1 The SPG shall be an independent entity performing its obligations pursuant to the Agreement.
- 17.8.2 Subject to the provisions of the Agreement, the SPG shall be solely responsible for the manner in which its obligations under this Agreement are to be performed. All employees and representatives of the SPG or contractors engaged by the SPG in connection with the performance of the Agreement shall be under the complete control of the SPG and shall not be deemed to be employees, representatives, contractors of DISCOM and nothing contained in the Agreement or in an

y agreement or contract awarded by the SPG shall be construed to create any contractual relationship between any such employees, representatives or contractors and DISCOM.

### **17.9 Compliance with Law**

17.9.1 Despite anything contained in this Agreement but without prejudice to this Article, if any provision of this Agreement shall be in deviation or inconsistent with or repugnant to the provisions contained in the Electricity Act, 2003, or any rules and regulations made there under, such provision of this Agreement shall be deemed to be amended to the extent required to bring it into compliance with the aforesaid relevant provisions as amended from time to time.

### **17.10 Order of priority in application**

17.10.1 In case of inconsistencies in the agreements executed between the Parties, applicable Law including rules and regulations framed there under, the order of priority shall be as mentioned below:

- (i) applicable Law, rules and regulations framed there under,
- (ii) this Agreement

### **17.11 Affirmation**

17.11.1 The SPG and, both affirm that;

- a) neither it nor its respective directors, employees, or agents has paid or undertaken to pay or shall in the future pay any unlawful commission, bribe, pay-off or kick-back; and
- b) it has not in any other manner paid any sums, whether in Indian currency or foreign currency and whether in India or abroad to the other Party to procure this Agreement, and the SPG and DISCOM hereby undertaken not to engage in any similar acts during the Term of Agreement.

### **17.12 No consequential or Indirect Losses**

17.14.1. The liability of the Seller and the Procurers is limited to that explicitly provided in this Agreement.

17.14.2. Provided that notwithstanding anything contained in this Agreement, under no events shall the Procurers or the Seller claim from one another any indirect or consequential losses or damages.

### **17.13 Breach of Obligations**

17.13.1 The Parties acknowledge that a breach of any of the obligations contained herein would result in injuries. The Parties further acknowledge that the amount of the liquidated damages or the method of calculating the liquidated damages specified in this Agreement is a genuine and reasonable pre-estimate of the damages that may be suffered by the non-defaulting party in each case specified under this Agreement.

**17.14 Books and Records:** *The SPG shall maintain books of account relating to the Project in accordance with generally accepted Indian accounting principles.*

**17.15 Limitation Remedies and Damages:** *Neither Party shall be liable to the other for any consequential, indirect or special damages to persons or property whether arising in tort, contract or otherwise, by reason of this Agreement or any services performed or undertaken to be performed hereunder.*

**17.16 Severability:** *Any provision of this Agreement, which is prohibited or unenforceable in any jurisdiction, shall, as to such jurisdiction, be ineffective to the extent of such prohibition or unenforceability without invalidating the remaining provisions hereof and without affecting the validity, enforceability or legality of such provision in any other jurisdiction.*

**17.17 Entire Agreement, Appendices:** *This Agreement constitutes the entire agreement between DISCOM and the SPG, concerning the subject matter hereof. All previous documents, undertakings, and agreements, whether oral, written, or otherwise, between the Parties concerning the subject matter hereof are hereby cancelled and shall be of no further force or effect and shall not affect or modify any of the terms or obligations set forth in this Agreement, except as the same may be made part of this Agreement in accordance with its terms, including the terms of any of the appendices, attachments or exhibits. The appendices, attachments and exhibits are hereby made an integral part of this Agreement and shall be fully binding upon the Parties.*

*In the event of any inconsistency between the text of the Articles of this Agreement and the appendices, attachments or exhibits hereto or in the event of any inconsistency between the provisions and particulars of one appendix, attachment or exhibit and those of any other appendix, attachment or exhibit DISCOM and the SPG shall consult to resolve the inconsistency.*

**17.18 Further Acts and Assurances:** *Each of the Parties after convincing itself agrees to execute and deliver all such further agreements, documents and instruments, and to do and perform all such further acts and things, as shall be necessary or convenient to carry out the provisions of this Agreement and to consummate the transactions contemplated hereby.*

IN WITNESS WHEREOF the Parties have caused the Agreement to be executed through their duly authorized representatives as of the date and place set forth above.

Signature

Signature with Seal

\_\_\_\_\_  
Solar Power Generator  
Witness:

UTTAR Gujarat Vij Company Ltd.  
DISCOM  
Witness: